

# END-CONTROLLED RIDER PALLET JACK



# GOES THE DISTANCE, HANDLES ALL THE STOPS

- ▶ 6000 - 8000 lb. Capacity  
On Level Surfaces
- ▶ AC Drive Motor
- ▶ 144 in. Fork Option
- ▶ Fork Height Travel Interlock



8HBE30-40

# LONG ON PRODUCTIVITY

**THE TOYOTA END-CONTROLLED RIDER.** From one end of the warehouse to the other, it delivers. Maneuvering loads easily, making long runs efficiently. The End-Controlled Rider also handles multiple stops comfortably. The key? Locating the operator platform at the end of the pallet jack, for easier entry and exit — a benefit that helps the End-Controlled Rider excel as a low-level order picker, too. Goods, delivered. Productivity, boosted.

## END-CONTROLLED RIDER ADVANTAGES

- ▶ **MULTIFUNCTION CONTROL HANDLE** with ergonomically positioned handgrips, dual thumbwheels, and lift, lower, and horn buttons for simplified operation of all controls with either hand
- ▶ **HIGH-SPEED INTERLOCK** to maintain top travel speed for long-distance transport
- ▶ **PROGRAMMABLE PERFORMANCE PARAMETERS** customizable through a digital display to adjust for a variety of job applications
- ▶ **BOX RAIL FORK CONSTRUCTION** provides torsional rigidity and maximum strength
- ▶ **LITHIUM-ION BATTERY OPTIONS** require less maintenance and allow for opportunity charging to increase uptime
- ▶ **DUAL LIFT CYLINDERS** provide efficient hydraulic power for smooth, effortless lifting to reduce component wear
- ▶ **OPTIONAL POWER STEERING** for effortless steering, improved ergonomics, and unmatched control
- ▶ **GLANCE & GO DISPLAY** provides a quick summary of key information

144<sup>IN.</sup>  
FORK OPTION

UP TO 8000<sup>LB.</sup>  
CAPACITY ON LEVEL SURFACES

▶ **CUSHIONED HANDRAIL** offers convenient control during high-speed travel

▶ **ELECTRONIC COAST CONTROL OPTION** augments productivity by eliminating the need for operator to pull handle down during floor-level order picking

▶ **LOW STEP HEIGHT** eases frequent entry and exit during floor-level order picking for operator comfort

▶ **COLD CONDITIONING PACKAGE OPTION** includes cold storage-specific oil, greasable steer bearing and linkage bushings, and stainless steel linkage pins for use in cold storage environments



# END-CONTROLLED RIDER PALLET JACK

**CAPACITY**  
**6000 – 8000 LBS.**  
on level surfaces

**FORK SIZE RANGE**  
**36 – 144 IN.**

**FORK OVERALL WIDTH**  
**22 – 27.5 IN.**

## INDUSTRIES



Beverage



Cold Storage



Food Storage



General  
Warehousing



Retail

## STANDARD FEATURES

### PERFORMANCE

- AC drive motor with thermal protection & current limiting
- 24-Volt electrical system
- 6" lift
- Hour meter reading
- Regenerative plugging
- Programmable performance
- Adjustable maximum speed
- Adjustable acceleration
- On/off key switch
- Lift limit switch
- Multiple hour meter indicator
- Battery discharge indicator with lift interrupt
- Fused control & power circuits
- Hydraulic overload protection valve
- Dual 1.25"-dia. lift cylinders
- Drive-thru freezer curtain feature
- Polyurethane torsion block stabilizing casters<sup>1</sup>
- Heavy-duty spring-loaded stabilizing casters<sup>2</sup>

### BODY/EXTERIOR DESIGN

- 31.5"-long x 13.44"-wide battery compartment<sup>3</sup>
- SB-175 battery connector (gray)
- Top Adjust Caster Wheels
- Heavy Duty Casters<sup>4</sup>

### ERGONOMICS

- Multifunction control handle with ergonomically angled handgrips & wrap-around hand guard
- Soft-cushioned rider platform
- Low platform step height
- Dual thumbwheels with twist grips for directional control & travel speed
- Intuitively positioned lift/lower buttons
- Curvilinear handrail with push buttons for lift, lower, horn & high-speed functions
- Low-effort control handle
- High-speed interlock button
- Knee pad

### DURABILITY

- Control Area Network (CAN-bus) communications
- Welded construction with reinforced heavy-duty bumper
- Powder coat paint finish
- Box rail fork construction
- Steel gussets reinforced rider platform
- Steel bulkhead wrappers
- Forged rectangular steel tension rods
- Heavy-duty bushings & pins
- Solid trail fork casting
- Tapered fork tips with pallet entry slides
- Four-point lift linkage
- High-strength polymer service cover
- Rubber drive tire
- Hall-effect switches
- Fork Height Travel Interlock

### SERVICEABILITY

- AC drive motor (no brushes or commutator)
- One-piece, lightweight service access cover
- Error indicator with self-diagnostics
- Self-adjusting electric disc brake
- Teflon<sup>®</sup>-coated Polylube<sup>™</sup> lift linkage bushings (maintenance free)

### SUPPORT

- Handrail with lift, lower, horn & high-speed functions
- Wrap-around hand guard
- Spring-loaded control handle
- Runaway protection
- Electronic horn
- Directional reverse switch on control handle

<sup>1</sup> Standard only with fork lengths below 84" (2134 mm).

<sup>2</sup> Standard only with fork lengths 84" (2134 mm) & above.

<sup>3</sup> Battery compartment width is 30.25" (768 mm) when equipped with optional battery compartment rollers

<sup>4</sup> Standard only with fork lengths 96" (2438 mm) & above

## OPTIONAL EQUIPMENT

- 48," 60" and 72" load backrest extension
- Electronic travel alarm (forward & reverse)
- Controller splash guard
- Keyless on/off switch
- Electronic touchpad, keyless entry system with password protection
- Power hookup for onboard terminal (24-Volt, 2 amp)
- Power hookup for onboard terminal (24-Volt, 10 amp)
- Storage tray, load backrest mounted
- Storage tray, battery compartment mounted
- Coast control with jog buttons
- Turtle speed (3-position key switch)
- Rubber front bumper skirt
- Pallet entry/exit rollers (single length pallet forks only 36"- 60")
- Storage tray & stretch wrap holder, load backrest mounted
- Steering bearing, greaseable
- Lubrication package for pivot points (grease fittings)
- Battery compartment rollers with dual side gates
- Battery side gate interlock switches
- Battery spacer kit
- Polyurethane drive tire
- Non-marking rubber drive tire
- Heavy-duty load wheels (Vulkollan®)
- Tandem dual load wheels (3.25" x 2")
- Load wheel debris diversion device
- Polyurethane load wheels (tan durometer 95)
- Load wheels, single axle/dual
- Load wheels, single axle/triple
- Cold storage conditioning
- Galvanized chassis
- Galvanized chassis with cold storage
- Special paint color, complete truck
- UL-approved model type "E"
- UL-approved model type "EE"
- Factory pre-programmed maximum travel speed of 5 mph
- Power steering
- Various travel alarms
- Various drive tire options
- Accessory bar, single tier
- Various battery connector options
- Casters w/ food grade grease
- 2nd level pick steps
- Rubber bumper skirt, solid
- Magnetic storage tote
- Universal tapered forks
- Heavy-duty bumper guard

Please contact your local, authorized Toyota Dealer for a complete list of available options.



# TRUCK SPECIFICATIONS

GENERAL DATA		MODEL NUMBER											
GENERAL DATA		8HBE30											
Load Capacity	lb (kg)	6000 (2725) on level surfaces											
Power Type		Battery											
Operator Position		End-Controlled Walkie / Rider											
Tire Type	Drive / Caster / Load	Rubber / Polyurethane / Polyurethane											
Wheels (x = driven)	Front / Rear	1 Drive, 2 Heavy-Duty Casters / 2 Load											
EXTERIOR DIMENSIONS		8HBE30											
<b>A</b> Fork Length	in (mm)	32 (813) <sup>4</sup>	36 (914) <sup>4</sup>	42 (1067) <sup>4</sup>	48 (1220) <sup>4</sup>	60 (1524) <sup>4</sup>	84 (2134) <sup>1,5</sup>	93 (2362) <sup>1,5</sup>	96 (2438) <sup>1,5</sup>	103 (2616) <sup>1,2,5</sup>			
<b>B</b> Overall Length	in (mm)	74.4 (1890)	78.4 (1991)	84.4 (2144)	90.4 (2296)	102.4 (2600)	127.8 (3222)	136.8 (3474)	138.8 (3525)	145.8 (3703)			
<b>C</b> Wheelbase	Lowered	in (mm)	50.8 (1290)	54.8 (1392)	60.8 (1544)	66.8 (1697)	78.8 (2002)	87.6 (2225)	87.6 (2225)	94.6 (2403)			
	Raised	in (mm)	46.1 (1171)	50.1 (1273)	56.1 (1425)	62.1 (1577)	74.1 (1882)	82.9 (2106)	82.9 (2106)	89.9 (2283)			
<b>E</b> Turning Radius	in (mm)	61.9 (1572)	65.8 (1671)	71.7 (1821)	77.5 (1969)	89.4 (2271)	98.9 (2512)	98.9 (2512)	98.9 (2512)	105.8 (2687)			
<b>F</b> Overall Fork Width	in (mm)	22 (559) or 24 (610) or 27 (686)					22.625 (575) or 24.5 (622) or 27.5 (699)						
<b>G</b> Fork Width	in (mm)	9 (229)					10 (254)						
	Lowered	in (mm)	3.25 (83)										
	Raised	in (mm)	9.25 (235)										
Fork Lift	in (mm)	6 (152)											
Overall Width	in (mm)	36 (914)											
Gross Weight Without Battery	lb (kg)	1146 (520)	1190 (540)	1212 (550)	1234 (560)	1284 (582)	1360 (617)	1400 (635)	1410 (640)	1440 (653)			
Head Length	in (mm)	42.8 (1088)					43.3 (1100)						
Power Unit Height	in (mm)	31.4 (798)											
Overall Height	in (mm)	56.7 (1440)											
Operator's Platform Height	in (mm)	10.25 (260)											
Distance from Control Handle to Floor (lowered position)	in (mm)	37.7 (958)											
Distance from Bumper to Center of Drive Tire	in (mm)	16.1 (409)											
Bumper Underclearance	in (mm)	4.5 (114)											
Bumper Height	in (mm)	10.0 (254)											
PERFORMANCE DATA		8HBE30											
Speeds	Full Load	mph (km/h)	6.5 (10.5)										
	No Load	mph (km/h)	9.0 (14.5)										
Gradeability	Full Load	%	10										
	No Load	%	10										
TIRES		8HBE30											
Tires	Number	Front / Rear	3 / 2										
	Size (dia. x width)	Drive (front)	in (mm)	12 x 4.75 (305 x 121)									
		Caster (front)	in (mm)	4 x 2.5 (102 x 64)									
		Load (rear)	in (mm)	3.25 x 5.91 (83 x 150)									
POWER SYSTEM		8HBE30											
Battery	Voltage/Capacity	V / Ah	24 / 750										
	Connector (Color)		SB-175 (gray)										
	Connector Cable Location		B										
	Connector Cable Length	in (mm)	18 (457)										
Battery Compartment	Width	in (mm)	31.5 (800) <sup>3</sup>										
	Length	in (mm)	13.44 (341)										
	Height	in (mm)	-										
Battery Weight	Maximum	lb (kg)	1500 (680)										
	Minimum	lb (kg)	980 (445)										
Electric Motors	Drive (60 minutes)	hp (kW)	5.5 (4.1)										

1 Forks are designed to handle two 48" x 40" (1220 mm x 1016 mm) pallets.  
 2 These forks have a 7" (178 mm) longer wheelbase to allow for load overhang & proper load wheel drop.  
 3 Length = 30.25" (768 mm) when equipped with optional Battery Compartment Rollers.  
 4 Polyurethane Torsion Block Stabilizing Casters are standard.  
 5 Heavy-Duty Spring-Loaded Stabilizing Casters are standard.

# EXTERIOR DIMENSIONS

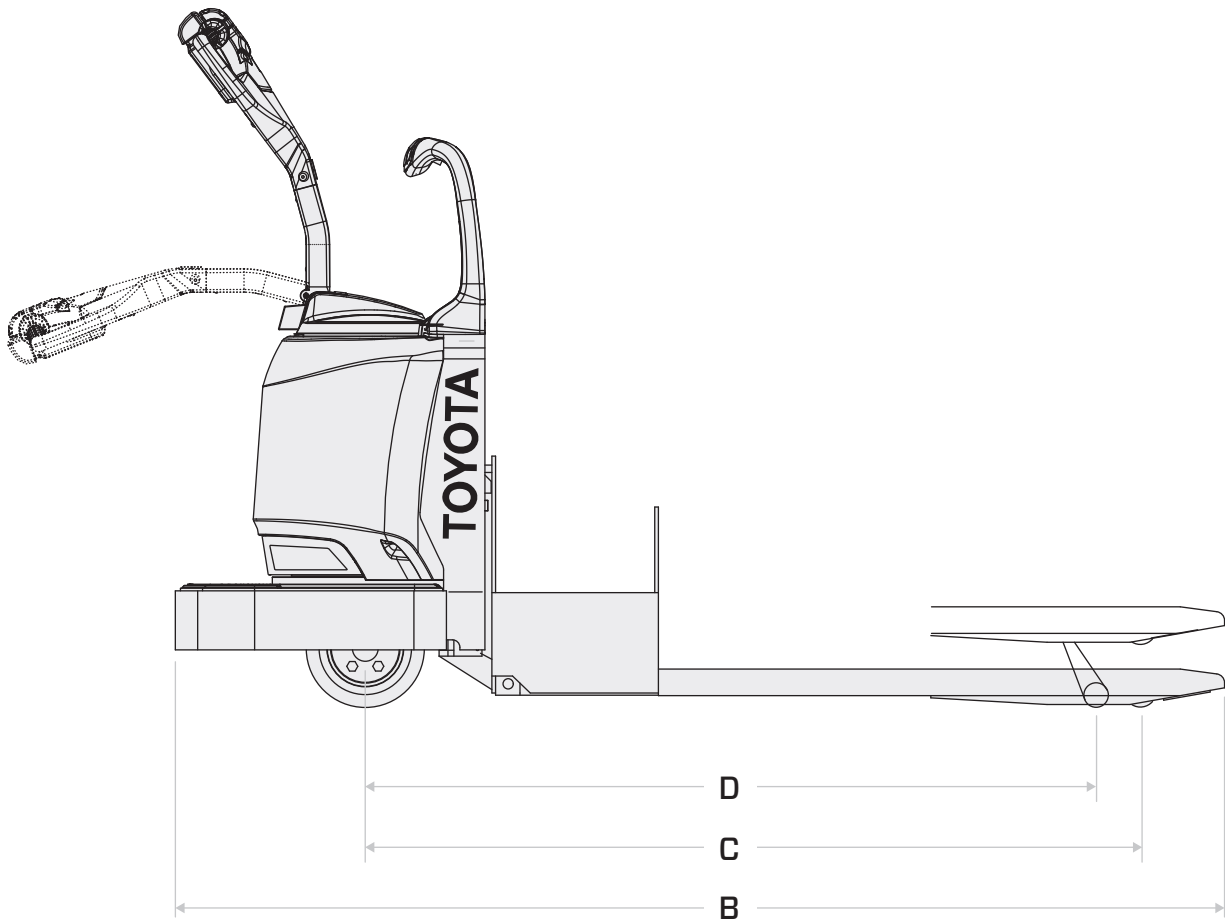
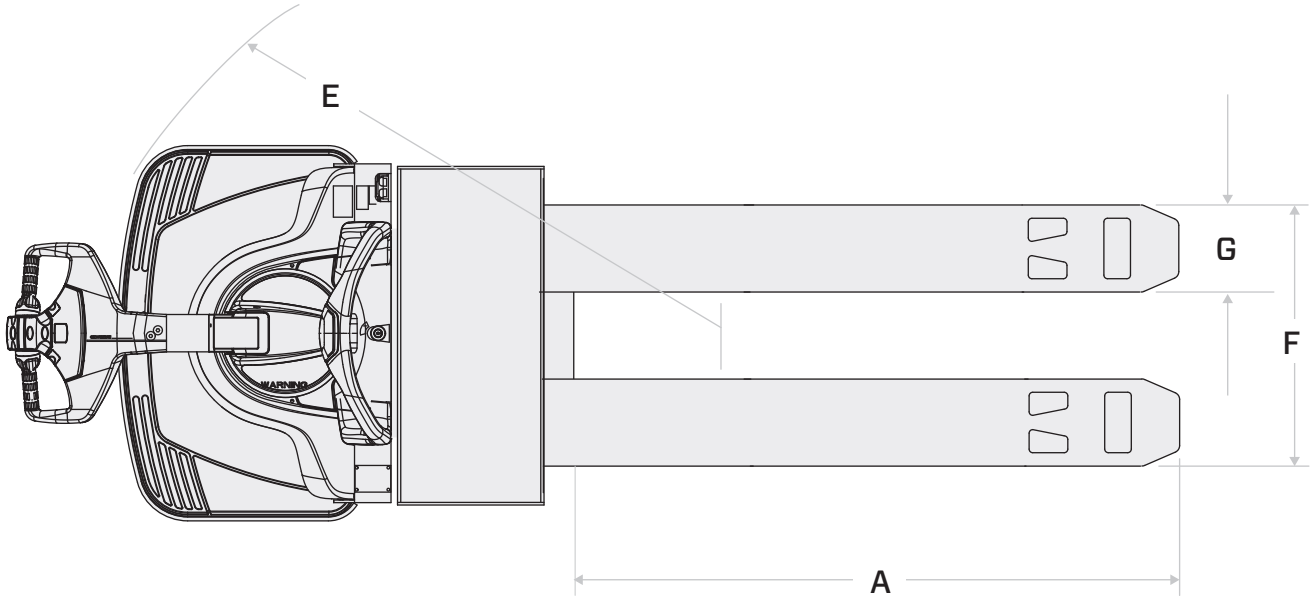

# TRUCK SPECIFICATIONS

GENERAL DATA			MODEL NUMBER					
GENERAL DATA			8HBE40					
Load Capacity	lb (kg)		8000 (3632) on level surfaces					
Power Type			Battery					
Operator Position			End-Controlled Walkie / Rider					
Tire Type	Drive / Caster / Load		Rubber / Polyurethane / Polyurethane					
Wheels (x = driven)	Front / Rear		1 Drive, 2 Heavy-Duty Casters / 2 Load					
EXTERIOR DIMENSIONS			8HBE40					
<b>A</b> Fork Length	in (mm)		36 (914) <sup>1</sup>	42 (1067) <sup>4</sup>	48 (1220) <sup>4</sup>	60 (1524) <sup>4</sup>	84 (2134) <sup>1,9</sup>	93 (2362) <sup>1,9</sup>
<b>B</b> Overall Length	in (mm)		78.4 (1991)	84.4 (2144)	90.4 (2296)	102.4 (2600)	127.8 (3222)	136.8 (3474)
<b>C</b> Wheelbase	Lowered	in (mm)	54.8 (1392)	60.8 (1544)	66.8 (1697)	78.8 (2002)	87.6 (2225)	87.6 (2225)
	Raised	in (mm)	50.1 (1273)	56.1 (1425)	62.1 (1577)	74.1 (1882)	82.9 (2106)	82.9 (2106)
<b>E</b> Turning Radius	in (mm)		65.8 (1671)	71.7 (1821)	77.5 (1969)	89.4 (2271)	98.9 (2512)	98.9 (2512)
<b>F</b> Overall Fork Width	in (mm)		27.5 (699)					
<b>G</b> Fork Width	in (mm)		6 (152)					
Fork Height	Lowered	in (mm)	3.25 (83)					
	Raised	in (mm)	9.25 (235)					
Fork Lift	in (mm)		6 (152)					
Overall Width	in (mm)		36 (914)					
Gross Weight Without Battery	lb (kg)		1190 (540)	1212 (550)	1234 (560)	1284 (582)	1570 (712)	1610 (730)
Head Length	in (mm)		43.3 (1100)					
Power Unit Height	in (mm)		31.4 (798)					
Overall Height	in (mm)		56.7 (1440)					
Operator's Platform Height	in (mm)		10.25 (260)					
Distance from Control Handle to Floor (lowered position)	in (mm)		37.7 (958)					
Distance from Bumper to Center of Drive Tire	in (mm)		16.1 (409)					
Bumper Underclearance	in (mm)		4.5 (114)					
Bumper Height	in (mm)		10.0 (254)					
PERFORMANCE DATA			8HBE40					
Speeds	Full Load	mph (km/h)	6.2 (10.0)					
	No Load	mph (km/h)	9.0 (14.5)					
Gradeability	Full Load	%	8					
	No Load	%	10					
TIRES			8HBE40					
Tires	Number	Front / Rear	3 / 2					
	Size (dia. x width)	Drive (front)	in (mm)	12 x 4.75 (305 x 121)				
		Caster (front)	in (mm)	4 x 2.5 (102 x 64)				
		Load (rear)	in (mm)	3.25 x 5.91 (83 x 150)				
POWER SYSTEM			8HBE40					
Battery	Voltage/Capacity	V / Ah	24/750					
	Connector (Color)		SB-175 (gray)					
	Connector Cable Location		B					
	Connector Cable Length	in (mm)	18 (457)					
Battery Compartment	Width	in (mm)	31.5 (800) <sup>6</sup>					
	Length	in (mm)	13.44 (341)					
Battery Weight	Maximum	lb (kg)	1500 (680)					
	Minimum	lb (kg)	980 (445)					
Electric Motors	Drive (60 minutes)	hp (kW)	5.5 (4.1)					

1 Forks are designed to handle two 48" x 40" (1220 mm x 1016 mm) pallets.  
 2 These forks have a 7" (178 mm) longer wheelbase to allow for load overhang & proper load wheel drop.  
 3 Forks are designed to handle three 40" x 48" (1016 mm x 1220 mm) pallets.  
 4 Forks are designed to handle three 48" x 40" (1220 mm x 1016 mm) pallets.  
 5 Tandem dual load wheels 3.25" x 2" (82.6 mm x 51 mm) are standard.  
 6 Length = 30.25" (768 mm) when equipped with optional Battery Compartment Rollers.  
 7 Load wheels drop into first slot of third pallet.  
 8 Load wheels drop into second slot of second pallet.  
 9 Heavy-Duty Spring-Loaded Stabilizing Casters are standard.

**MODEL NUMBER**

GENERAL DATA		8HBE40				
Load Capacity	lb (kg)	8000 (3632) on level surfaces				
Power Type		Battery				
Operator Position		End-Controlled Walkie / Rider				
Tire Type	Drive / Caster / Load	Rubber / Polyurethane / Polyurethane				
Wheels (x = driven)	Front / Rear	1 Drive, 2 Heavy-Duty Casters / 2 Load				

EXTERIOR DIMENSIONS		8HBE40				
<b>A</b> Fork Length	in (mm)	96 (2438) <sup>1,9</sup>	103 (2616) <sup>1,2,9</sup>	115 (2921) <sup>3,5,7,9</sup>	144 (3658) <sup>4,5,7,9</sup>	144 (3658) <sup>4,5,7,9</sup>
<b>B</b> Overall Length	in (mm)	138.8 (3525)	145.8 (3703)	158.8 (4033)	186.8 (4745)	186.8 (4745)
<b>C</b> Wheelbase	Lowered	in (mm)	87.6 (2225)	94.6 (2403)	119.8 (3043)	135.6 (3444)
	Raised	in (mm)	82.9 (2106)	89.9 (2283)	115.1 (2924)	130.9 (3325)
<b>D</b> Fork Height	in (mm)	82.9 (2106)	89.9 (2283)	115.1 (2924)	130.9 (3325)	130.9 (3325)
<b>E</b> Turning Radius	in (mm)	98.9 (2512)	105.8 (2687)	130.9 (3325)	146.9 (3731)	126.4 (3210)
<b>F</b> Overall Fork Width	in (mm)	27.5 (699)				
<b>G</b> Fork Width	in (mm)	6 (152)				
	Fork Height	Lowered	in (mm)	3.25 (83)		
	Raised	in (mm)	9.25 (235)			
Fork Lift	in (mm)	6 (152)				
Overall Width	in (mm)	36 (914)				
Gross Weight Without Battery	lb (kg)	1620 (735)	1650 (748)	1770 (803)	1870 (848)	1870 (848)
Head Length	in (mm)	43.3 (1100)				
Power Unit Height	in (mm)	31.4 (798)				
Overall Height	in (mm)	56.7 (1440)				
Operator's Platform Height	in (mm)	10.25 (260)				
Distance from Control Handle to Floor (lowered position)	in (mm)	37.7 (958)				
Distance from Bumper to Center of Drive Tire	in (mm)	16.1 (409)				
Bumper Underclearance	in (mm)	4.5 (114)				
Bumper Height	in (mm)	10.0 (254)				

PERFORMANCE DATA		8HBE40				
Speeds	Full Load	mph (km/h)	6.2 (10.0)			
	No Load	mph (km/h)	9.0 (14.5)			
Gradeability	Full Load	%	8			
	No Load	%	10			

TIRES		8HBE40				
Tires	Number	Front / Rear	3 / 2			
	Size (dia. x width)	Drive (front)	in (mm)	12 x 4.75 (305 x 121)		
		Caster (front)	in (mm)	4 x 2.5 (102 x 64)		
		Load (rear)	in (mm)	3.25 x 5.91 (83 x 150)		

POWER SYSTEM		8HBE40				
Battery	Voltage/Capacity	V / Ah	24/750			
	Connector (Color)		SB-175 (gray)			
	Connector Cable Location		B			
	Connector Cable Length	in (mm)	18 (457)			
Battery Compartment	Width	in (mm)	31.5 (800) <sup>6</sup>			
	Length	in (mm)	13.44 (341)			
Battery Weight	Maximum	lb (kg)	1500 (680)			
	Minimum	lb (kg)	980 (445)			
Electric Motors	Drive (60 minutes)	hp (kW)	5.5 (4.1)			

1 Forks are designed to handle two 48" x 40" (1220 mm x 1016 mm) pallets.  
 2 These forks have a 7" (178 mm) longer wheelbase to allow for load overhang & proper load wheel drop.  
 3 Forks are designed to handle three 40" x 48" (1016 mm x 1220 mm) pallets.  
 4 Forks are designed to handle three 48" x 40" (1220 mm x 1016 mm) pallets.  
 5 Tandem dual load wheels 3.25" x 2" (82.6 mm x 51 mm) are standard.  
 6 Length = 30.25" (768 mm) when equipped with optional Battery Compartment Rollers.  
 7 Load wheels drop into first slot of third pallet.  
 8 Load wheels drop into second slot of second pallet.  
 9 Heavy-Duty Spring-Loaded Stabilizing Casters are standard.

## RIGHT-ANGLE STACKING AISLE REQUIREMENTS

FORK LENGTH	PALLET LENGTH	PALLET WIDTH						
		30 (762)	32 (813)	36 (914)	40 (1016)	42 (1067)	44 (1118)	48 (1220)
in (mm)	in (mm)	in (mm)	in (mm)	in (mm)	in (mm)	in (mm)	in (mm)	in (mm)
<b>BHBE30</b>								
32 (813) <sup>1</sup>	32 (813)	91 (2311)	92 (2337)	94 (2388)	96 (2438)	96 (2438)	97 (2464)	99 (2515)
36 (914) <sup>1</sup>	36 (914)	73.4 (1864)	73.4 (1864)	73.4 (1864)	73.4 (1864)	73.4 (1864)	73.4 (1864)	73.4 (1864)
42 (1067) <sup>1</sup>	42 (1067)	79.4 (2017)	79.4 (2017)	79.4 (2017)	79.4 (2017)	79.4 (2017)	79.4 (2017)	79.4 (2017)
48 (1220) <sup>1</sup>	48 (1220)	85.4 (2169)	85.4 (2169)	85.4 (2169)	85.4 (2169)	85.4 (2169)	85.4 (2169)	85.4 (2169)
60 (1524) <sup>1</sup>	60 (1524)	97.4 (2474)	97.4 (2474)	97.4 (2474)	97.4 (2474)	97.4 (2474)	97.4 (2474)	97.4 (2474)
84 (2134) <sup>2,7</sup>	2 x 48 (2 x 1220)	130.0 (3302)	129.8 (3297)	129.6 (3292)	129.3 (3284)	129.1 (3279)	129.0 (3277)	128.7 (3269)
93 (2362) <sup>3,7</sup>	2 x 48 (2 x 1220)	139.2 (3536)	139.0 (3531)	138.8 (3526)	138.6 (3520)	138.4 (3515)	138.3 (3513)	138.1 (3508)
96 (2438) <sup>4,7</sup>	2 x 48 (2 x 1220)	142.3 (3615)	142.2 (3612)	142.0 (3607)	141.8 (3602)	141.7 (3599)	141.5 (3594)	141.3 (3589)
103 (2616) <sup>5-7</sup>	2 x 48 (2 x 1220)	149.3 (3792)	149.2 (3790)	149.0 (3785)	148.8 (3780)	148.7 (3777)	148.5 (3772)	148.3 (3767)

FORK LENGTH	PALLET LENGTH	PALLET WIDTH						
		30 (762)	32 (813)	36 (914)	40 (1016)	42 (1067)	44 (1118)	48 (1220)
in (mm)	in (mm)	in (mm)	in (mm)	in (mm)	in (mm)	in (mm)	in (mm)	in (mm)
<b>BHBE40</b>								
36 (914) <sup>1</sup>	36 (914)	95 (2413)	96 (2438)	97 (2464)	99 (2515)	100 (2540)	101 (2565)	102 (2591)
42 (1067) <sup>1</sup>	42 (1067)	100 (2540)	101 (2565)	103 (2616)	104 (2642)	105 (2667)	106 (2692)	108 (2743)
48 (1220) <sup>1</sup>	48 (1220)	106 (2692)	106 (2692)	108 (2743)	110 (2794)	111 (2819)	111 (2819)	113 (2870)
60 (1524) <sup>1</sup>	60 (1524)	117 (2972)	117 (2972)	119 (3023)	121 (3073)	122 (3099)	122 (3099)	124 (3150)
84 (2134) <sup>7,2</sup>	2 x 48 (2 x 1220)	130.0 (3302)	129.8 (3297)	129.6 (3292)	129.3 (3284)	129.1 (3279)	129.0 (3277)	128.7 (3269)
93 (2362) <sup>7,3</sup>	2 x 48 (2 x 1220)	139.2 (3536)	139.0 (3531)	138.8 (3526)	138.6 (3520)	138.4 (3515)	138.3 (3513)	138.1 (3508)
96 (2438) <sup>4,7</sup>	2 x 48 (2 x 1220)	142.3 (3615)	142.2 (3612)	142.0 (3607)	141.8 (3602)	141.7 (3599)	141.5 (3594)	141.3 (3589)
103 (2616) <sup>4,6,7</sup>	2 x 48 (2 x 1220)	149.3 (3792)	149.2 (3790)	149.0 (3785)	148.8 (3780)	148.7 (3777)	148.5 (3772)	148.3 (3767)
115 (2921) <sup>7,8,10,11</sup>	3 x 40 (2 x 1220)	160.3 (4072)	160.1 (4067)	159.7 (4056)	159.3 (4046)	159.1 (4041)	158.9 (4036)	158.6 (4028)
144 (3658) <sup>7,9,10,11</sup>	3 x 48 (2 x 1220)	190.3 (4834)	190.2 (4831)	190.0 (4826)	189.8 (4821)	189.7 (4818)	189.5 (4813)	189.3 (4808)
144 (3658) <sup>7,9,10,12</sup>	3 x 48 (2 x 1220)	191.0 (4851)	190.9 (4849)	190.8 (4846)	190.6 (4841)	190.6 (4841)	190.5 (4839)	190.3 (4834)

**Minimum Aisle Width for Right-Angle Stacking**  
 Includes 4" (102 mm) clearance on each side of load.  
 Add a minimum of 12" (305 mm) for easy maneuvering.

1 Polyurethane Torsion Block Stabilizing Casters are standard.  
 2 For two 48" x 40" (1220 mm x 1016 mm) pallets entered on the 40" (1016 mm) face, with a total of 12" (305 mm) of pallet overhanging the forks.  
 3 For two 48" x 40" (1220 mm x 1016 mm) pallets entered on the 40" (1016 mm) face, with a total of 3" (77 mm) of pallet overhanging the forks.  
 4 For two 48" x 40" (1220 mm x 1016 mm) pallets entered on the 40" (1016 mm) face.  
 5 For two 48" x 40" (1220 mm x 1016 mm) pallets entered on the 40" (1016 mm) face, with a total of 7" (178 mm) of load overhang.  
 6 These forks have a 7" (178 mm) longer wheelbase to allow for load overhang & proper load wheel drop.  
 7 Heavy-Duty Spring-Loaded Casters are standard.  
 8 For three 40" x 48" (1220 mm x 1016 mm) pallets entered on the 48" (1220 mm) face, with a total of 5" (127 mm) of pallet overhanging the forks.  
 9 For three 48" x 40" (1220 mm x 1016 mm) pallets entered on the 40" (1016 mm) face.  
 10 Tandem dual load wheels 3.25" x 2" (83 mm x 51 mm) are standard.  
 11 Load wheel drops into first slot of third pallet.  
 12 Load wheel drops into second slot of second pallet.



TRAIN

TOYOTA

POWERED

U3-122  
AT



“THE NAME ON MY SHIRT  
SAYS TOYOTA,  
BUT I WORK  
FOR YOU.”

Alan – 360 Technician, Atlas Toyota Material Handling, Chicago, IL



**HELP IS ALWAYS HERE WITH TOYOTA 360 SUPPORT.**

The industry’s best and most comprehensive dealer network quickly delivers Toyota Certified Technicians to your work site. These specially trained technicians can also help assess your warehouse and facility needs to recommend the right equipment for the job. And with the largest fleet of used and rental material handling products, Toyota 360 keeps your business running at full speed.

[ToyotaForklift.com/360-Support](http://ToyotaForklift.com/360-Support)



**YOUR BUSINESS IS RIDING ON IT**

Some product features described herein are optional. Please consult your dealer for specifications. Details of specifications and equipment are based on information available at time of printing and may change without notice. Photos may not reflect physical trucks.

